

sømcasa

Assembly Instruction

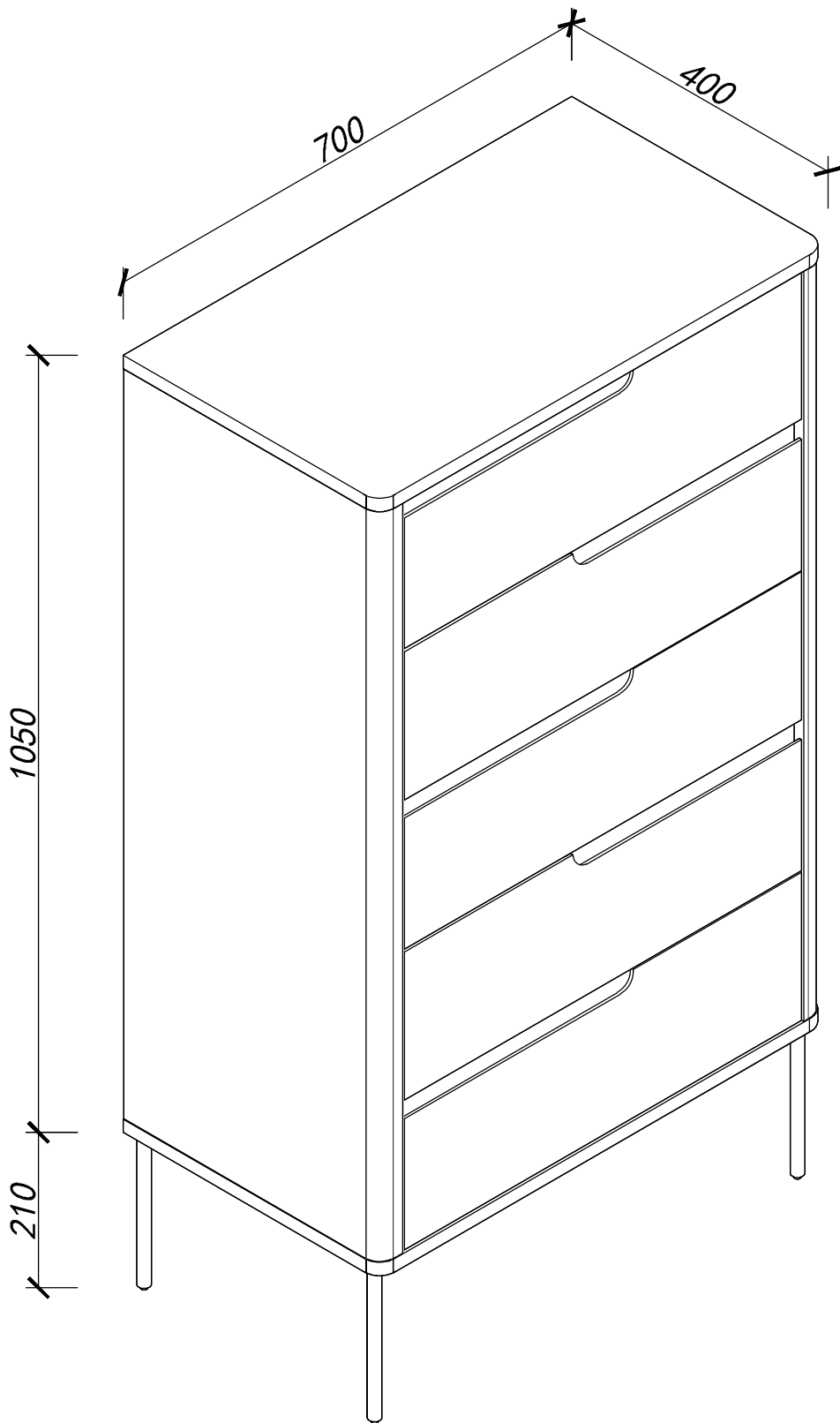

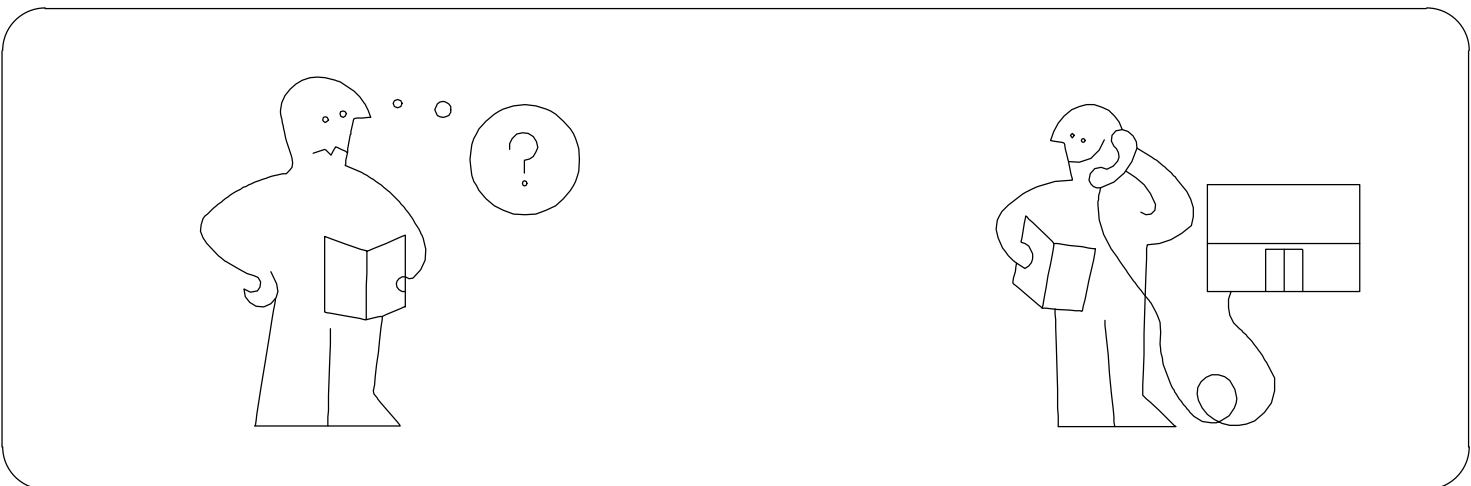
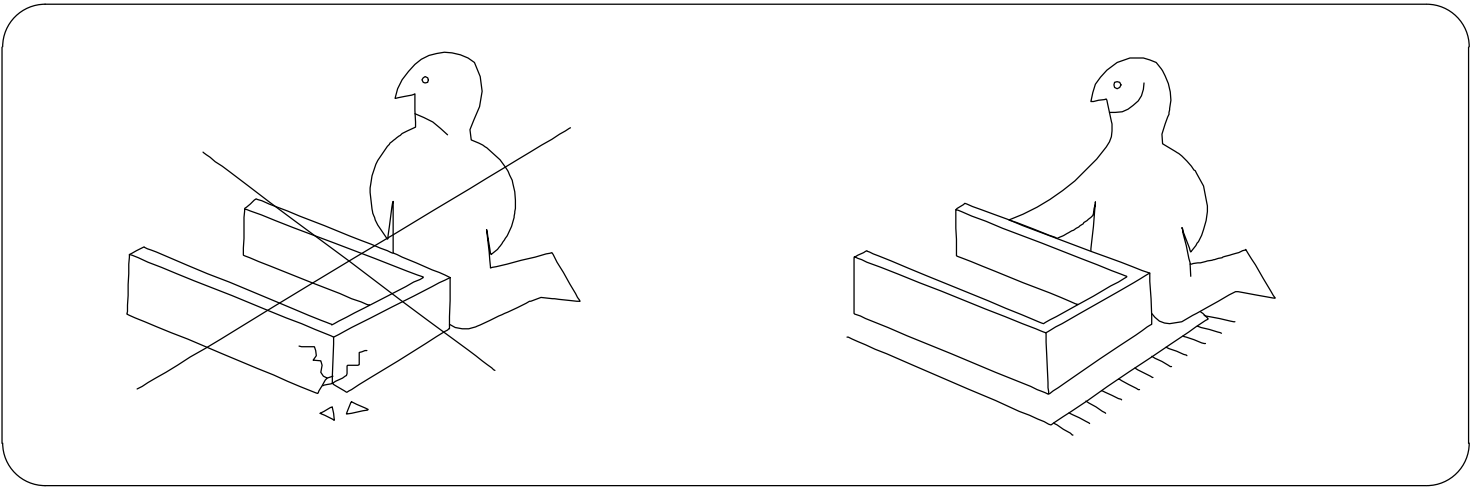
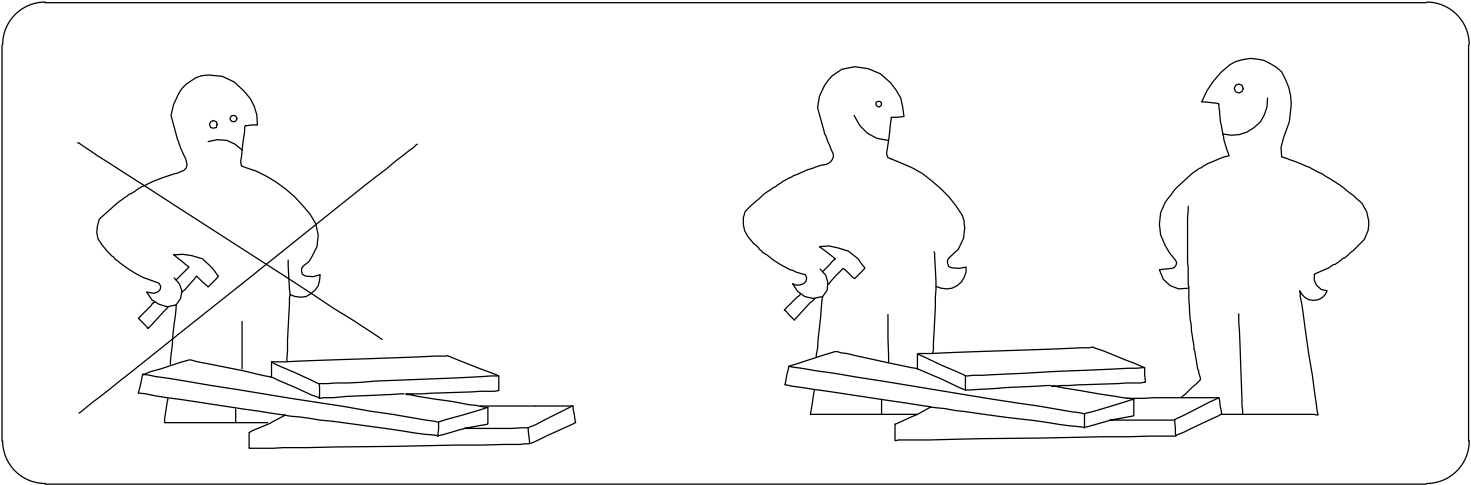
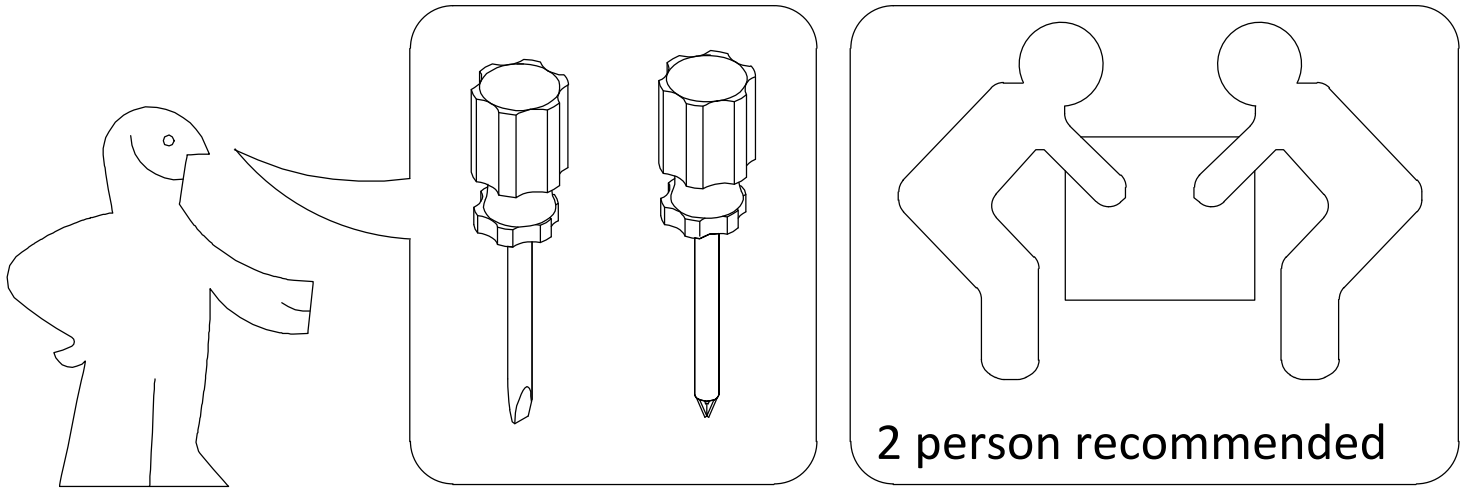

Panel No	Panel Sizes	Quantity
1	700*400*18	1
2	700*400*18	1
3	1014*399*36	1
4	1014*399*36	1
5	626*60*16	1
6	1014*100*16	1
7	1024*273*5	2

Panel No	Panel Sizes	Quantity
8	620*200*18	3
9	620*200*18	2
10	582*150*12	5
11	350*150*12	5
12	350*150*12	5
13	337*100*12	5
14	592*348*5	5

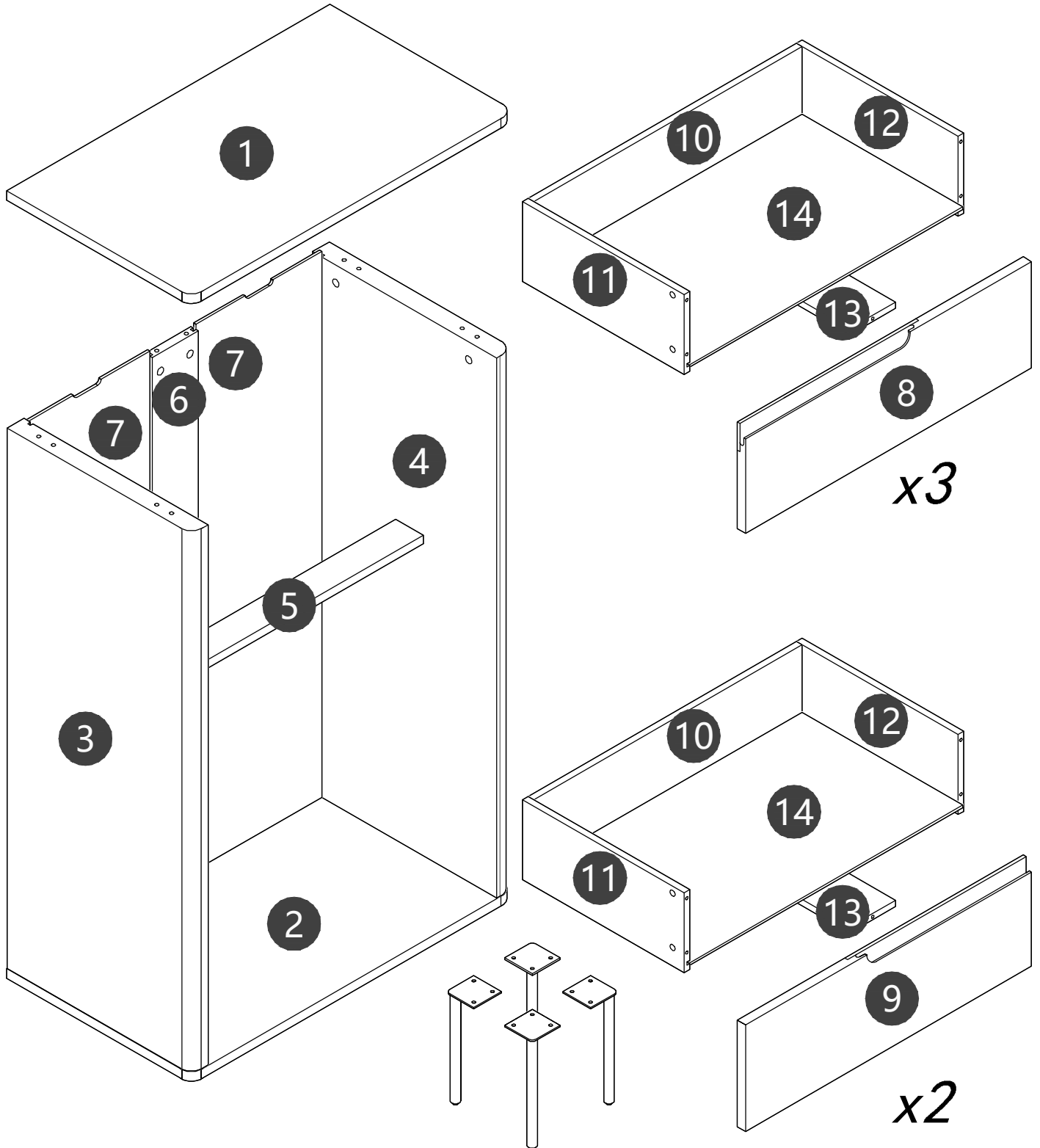

Fittings

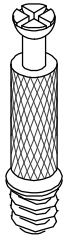

M6*40

A=8

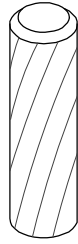

Φ8*30

B=10

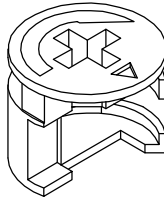

Φ15*12

C=8



Φ21

D=58

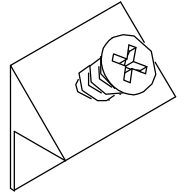

E=16

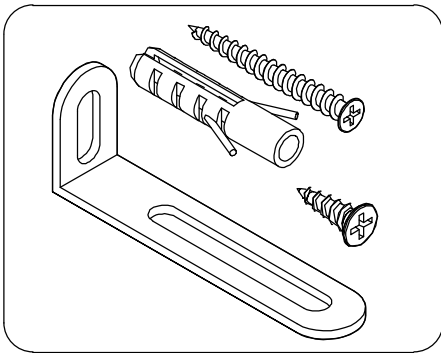

F=2

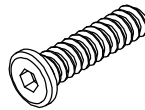

M6*16

G=12

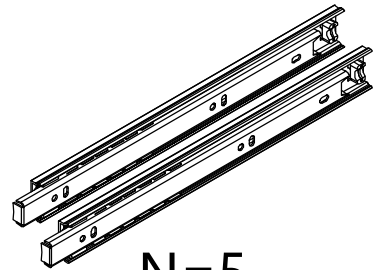

N=5



M4

H=1



M6*34

O=50

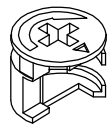

Φ12*10.5

P=50

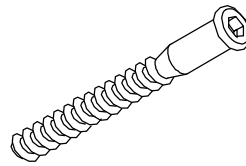

Φ7*50

Q=6

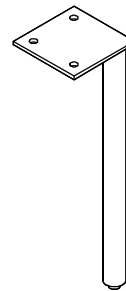

J=4



M3.5*12

V1=40



M4

Z1=12

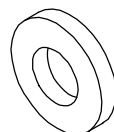

M4

Z2=12

STEP 1

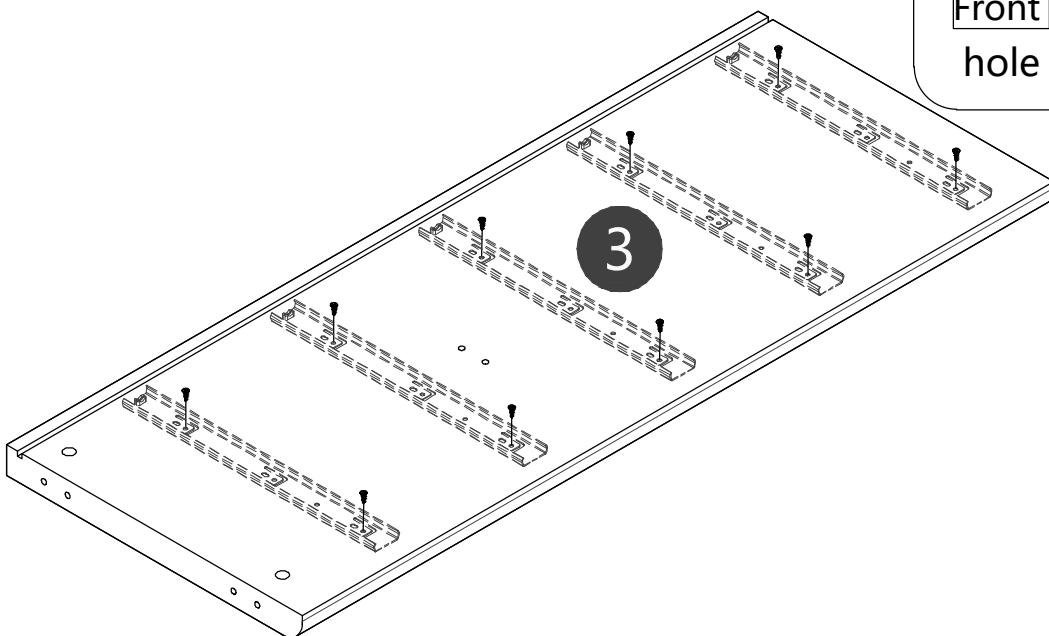
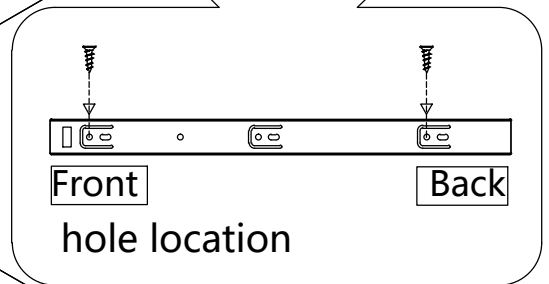
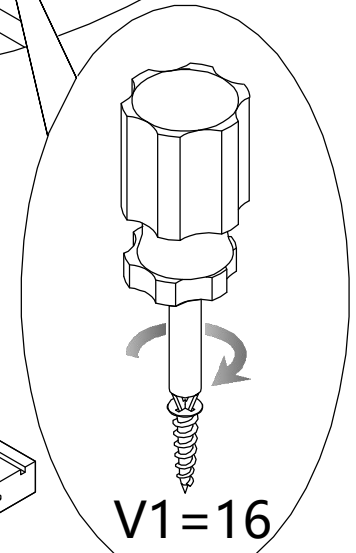
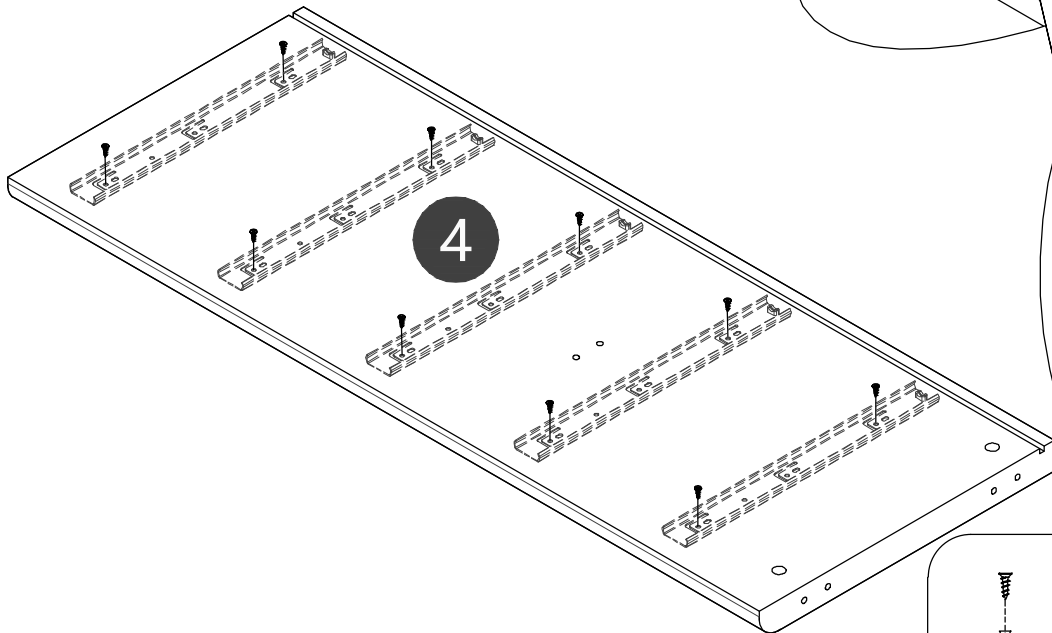
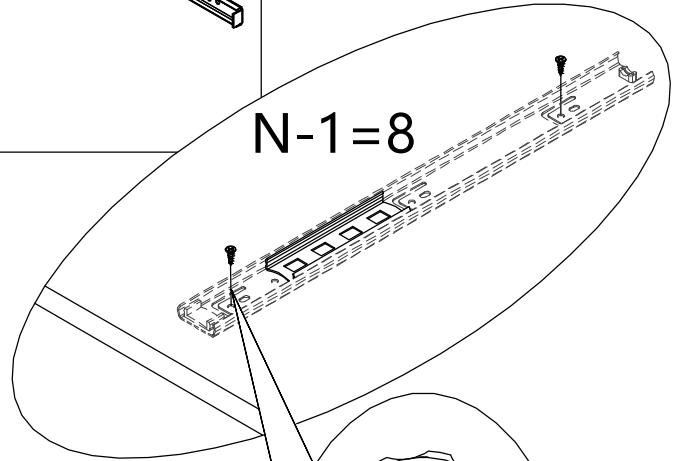
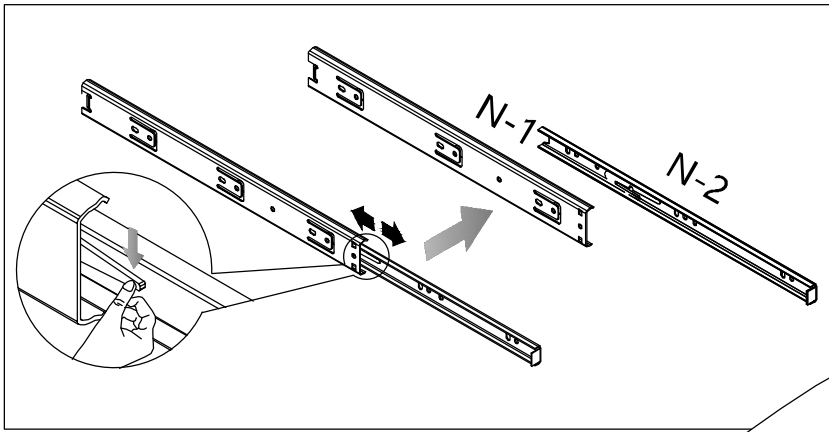

STEP 2

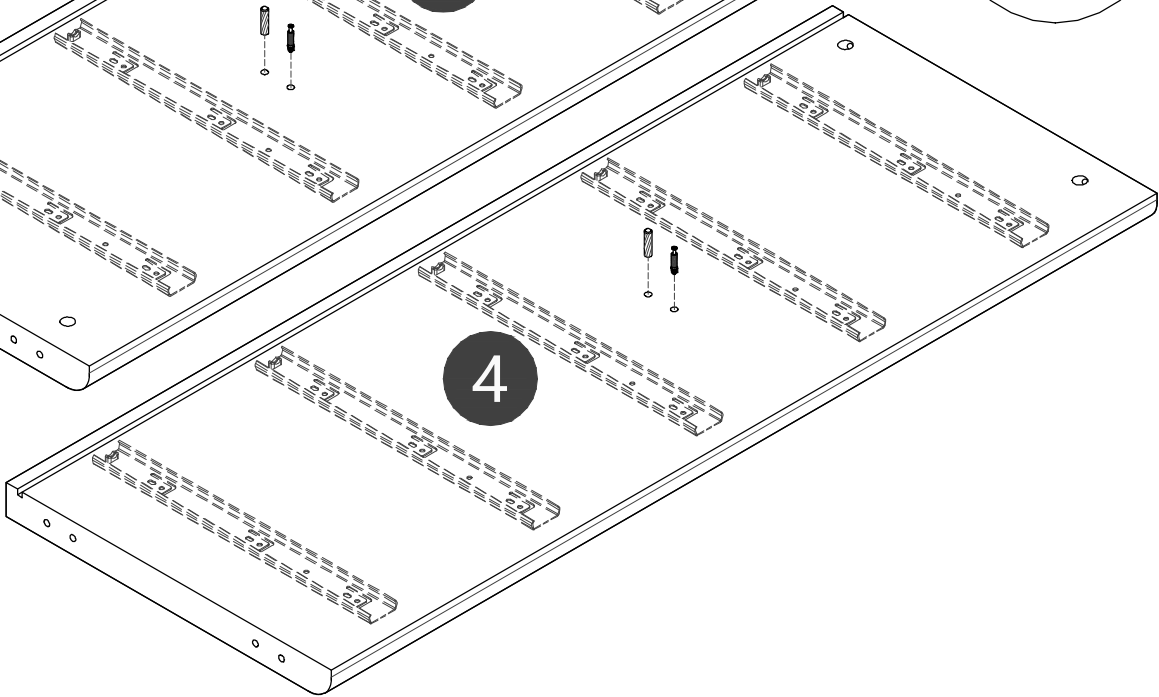
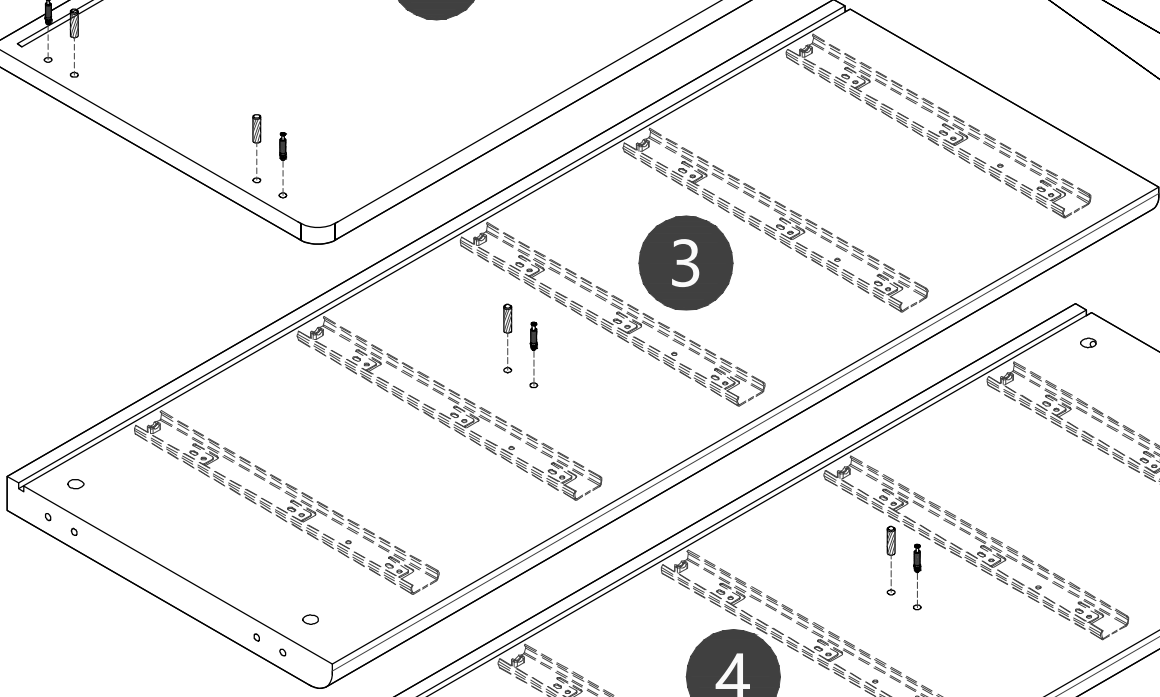
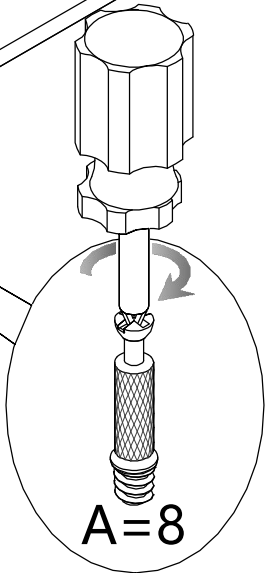
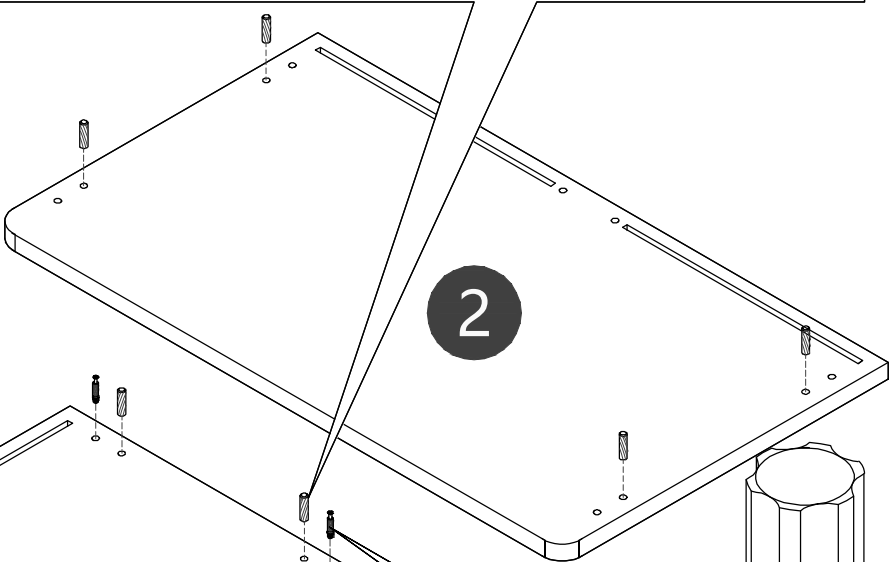
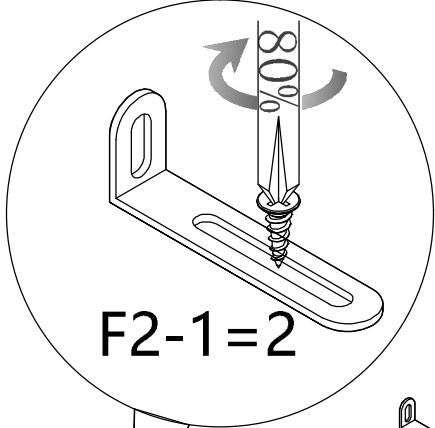
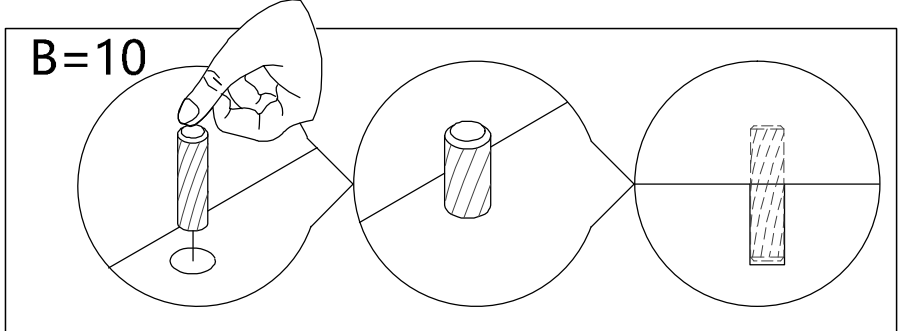

STEP 3

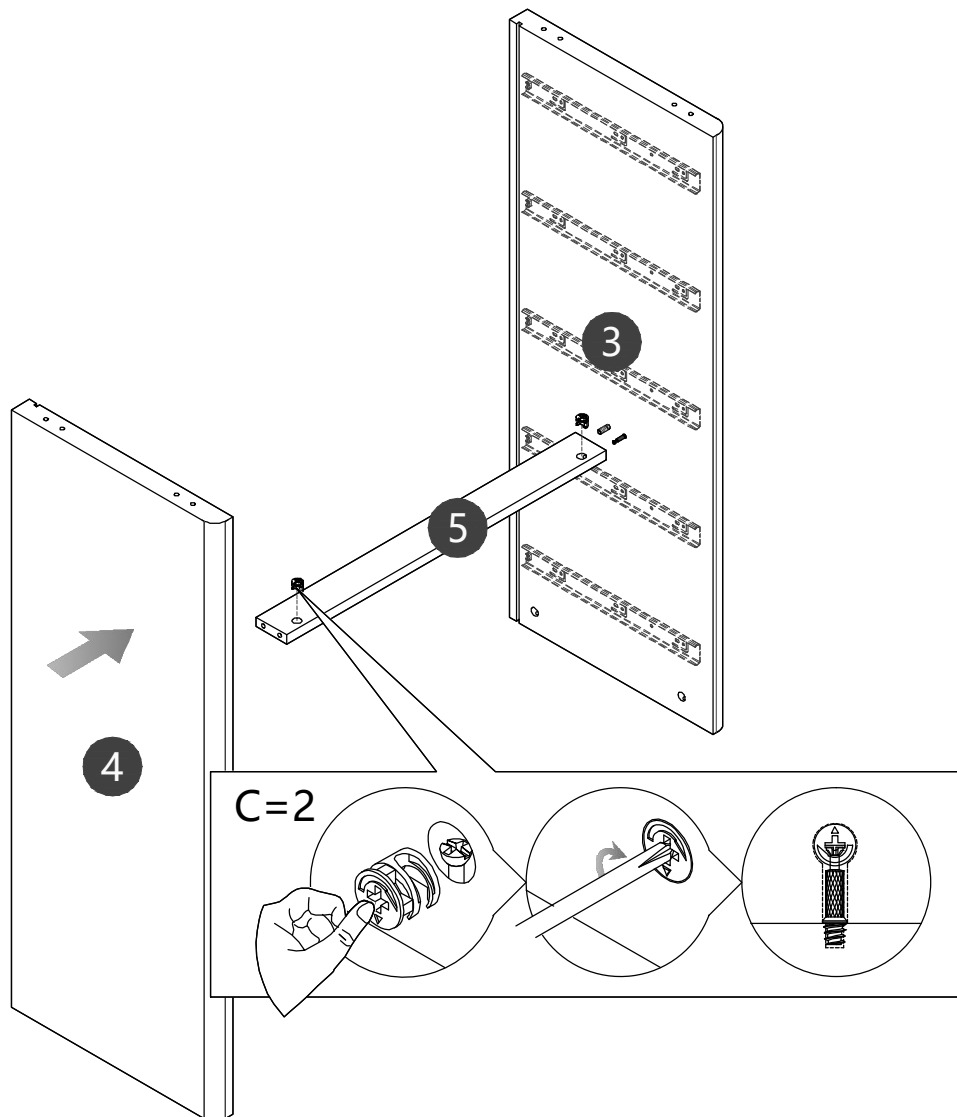

STEP 4

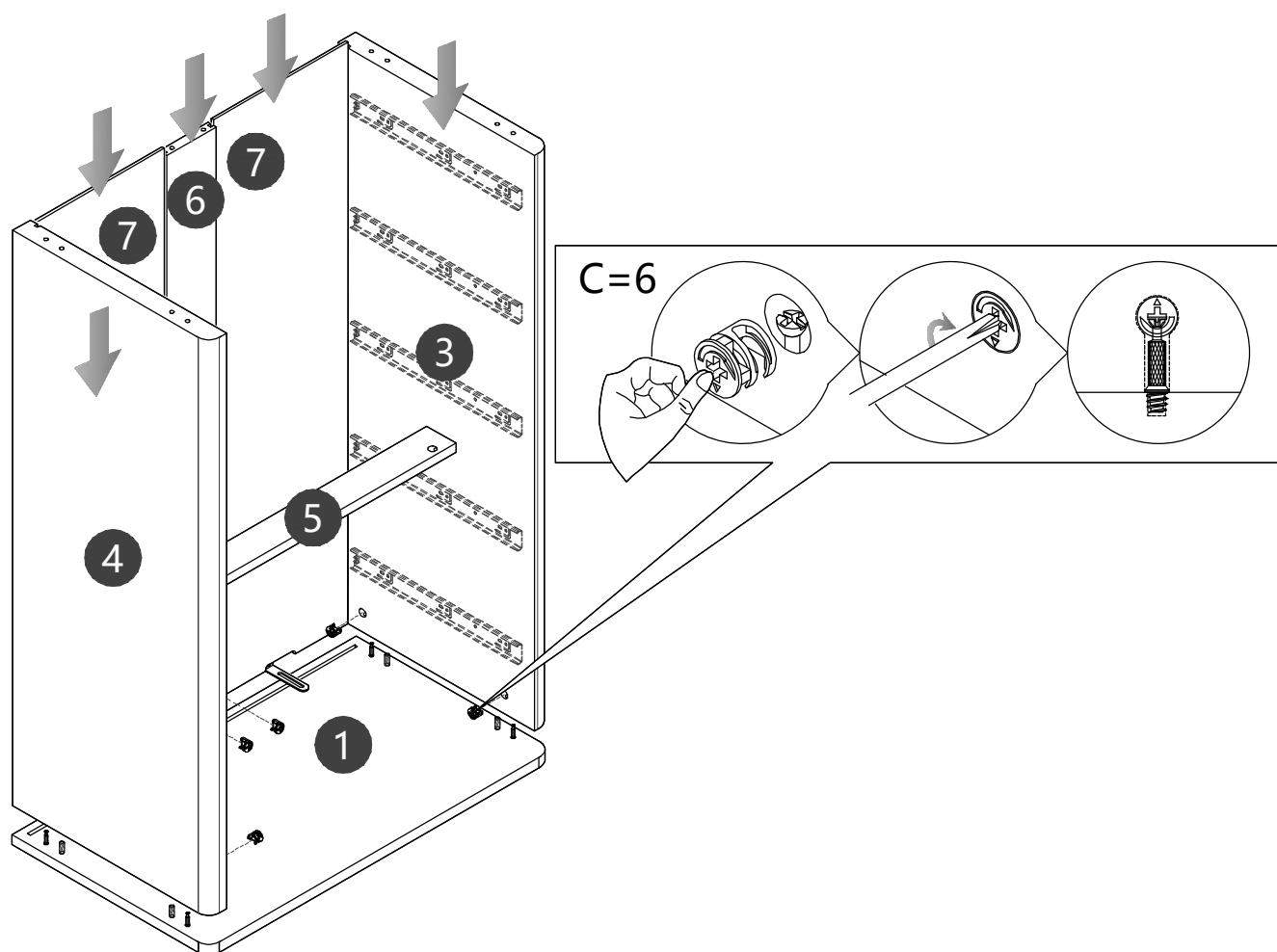

STEP 5

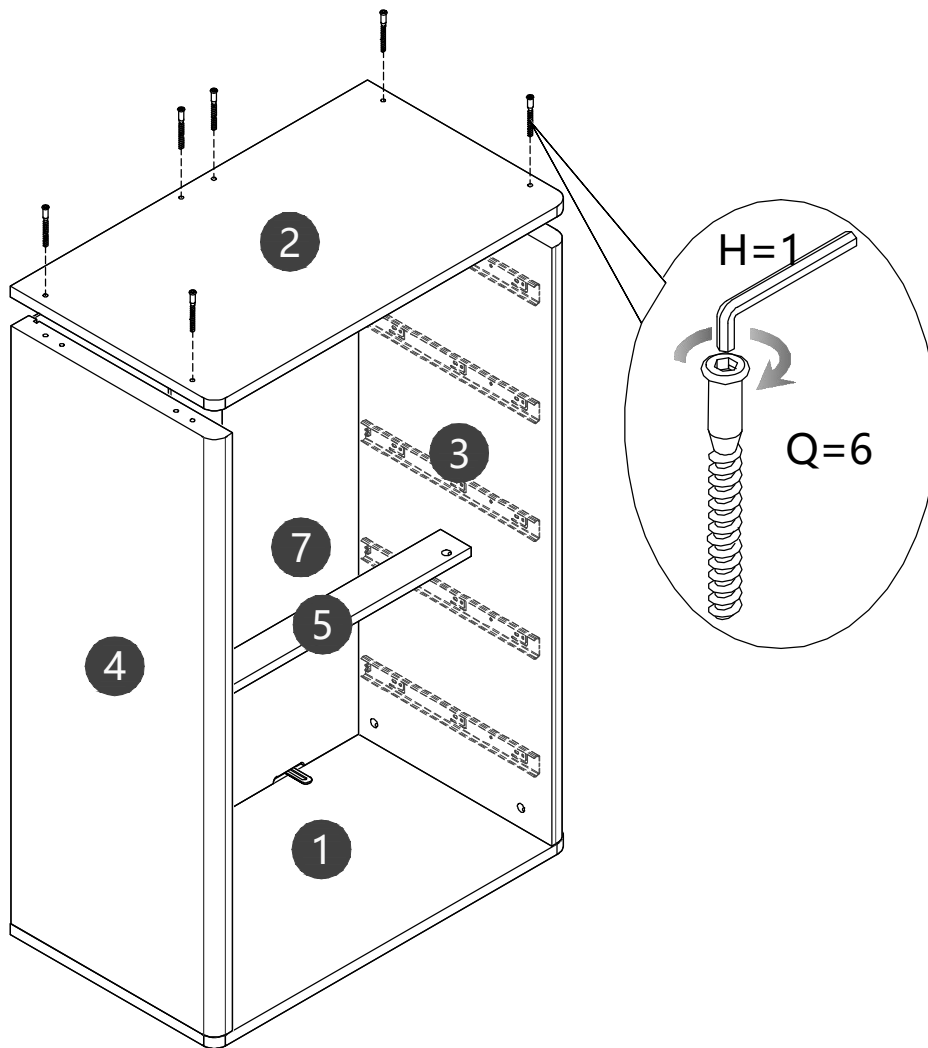

STEP 6

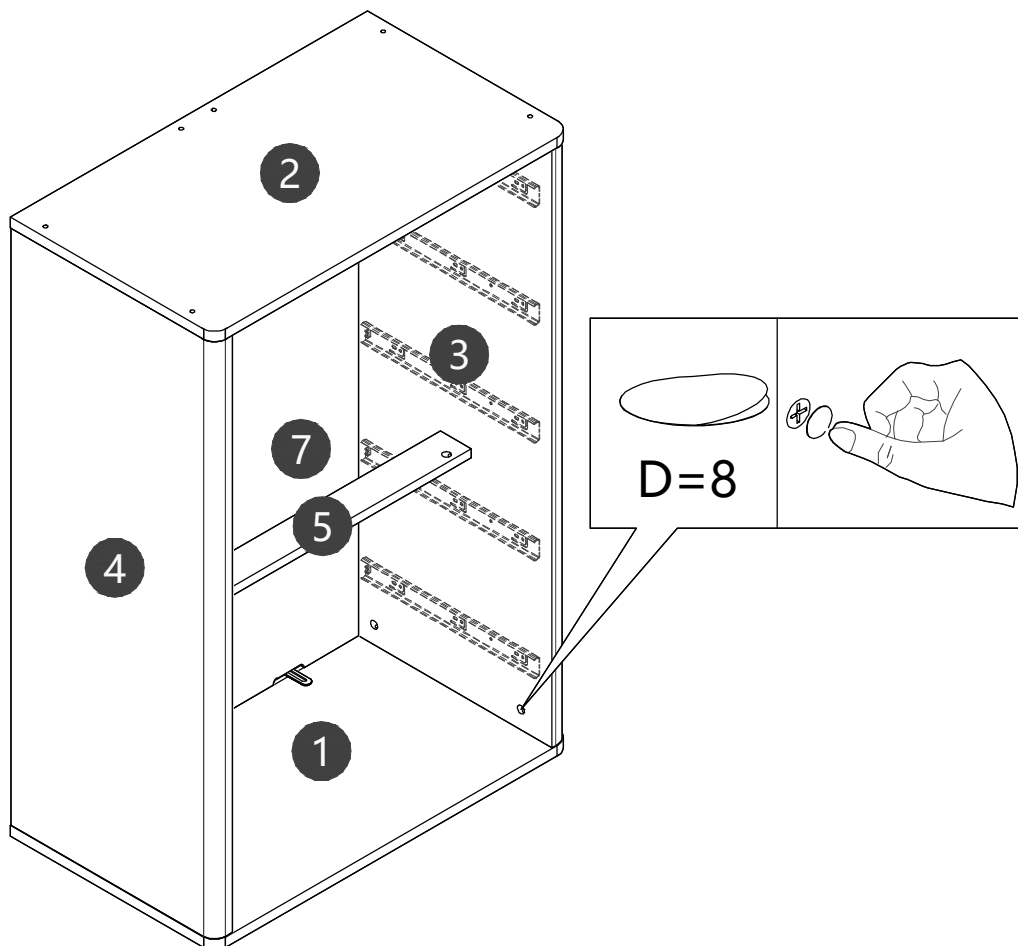

STEP 7

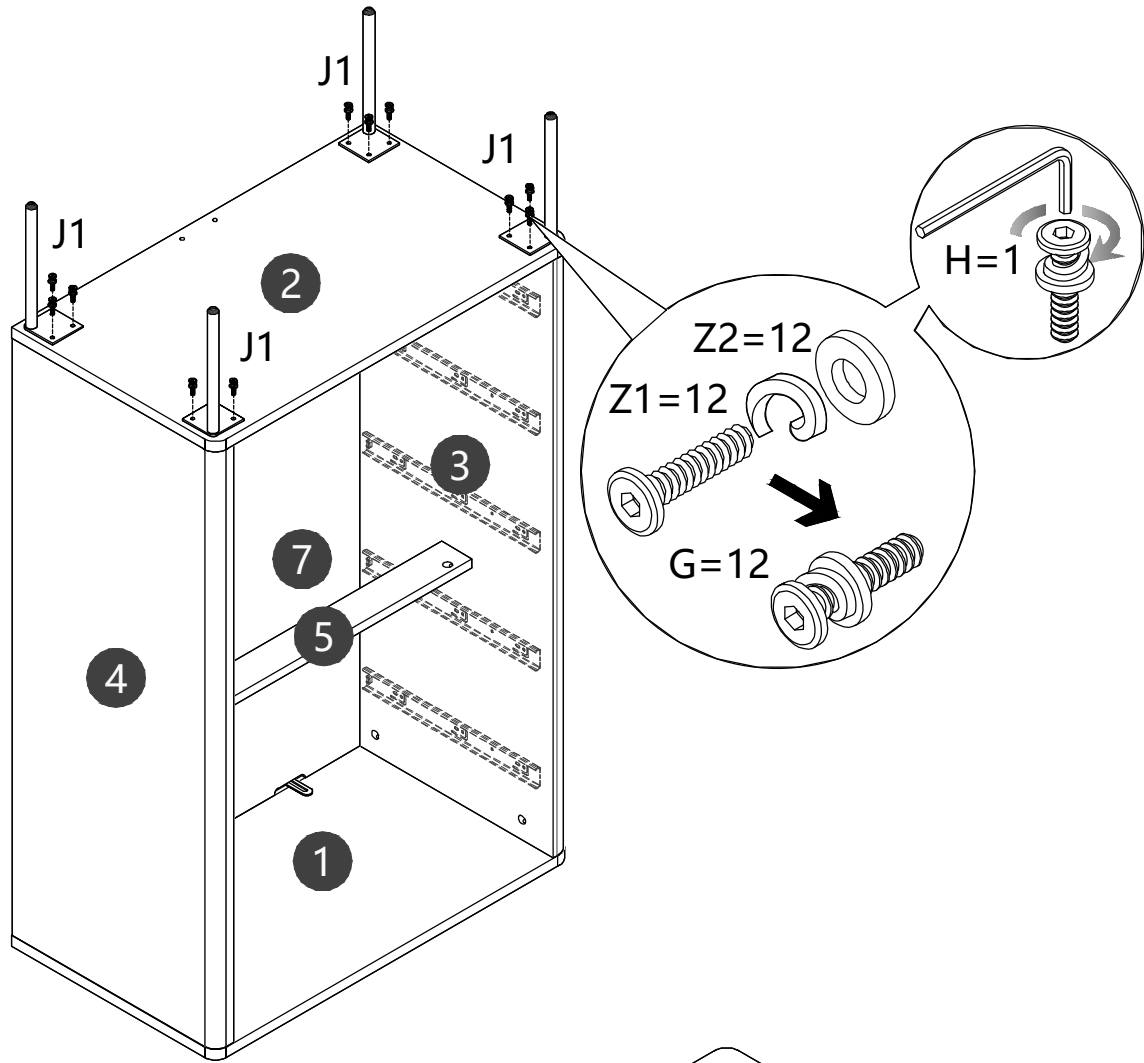

STEP 8

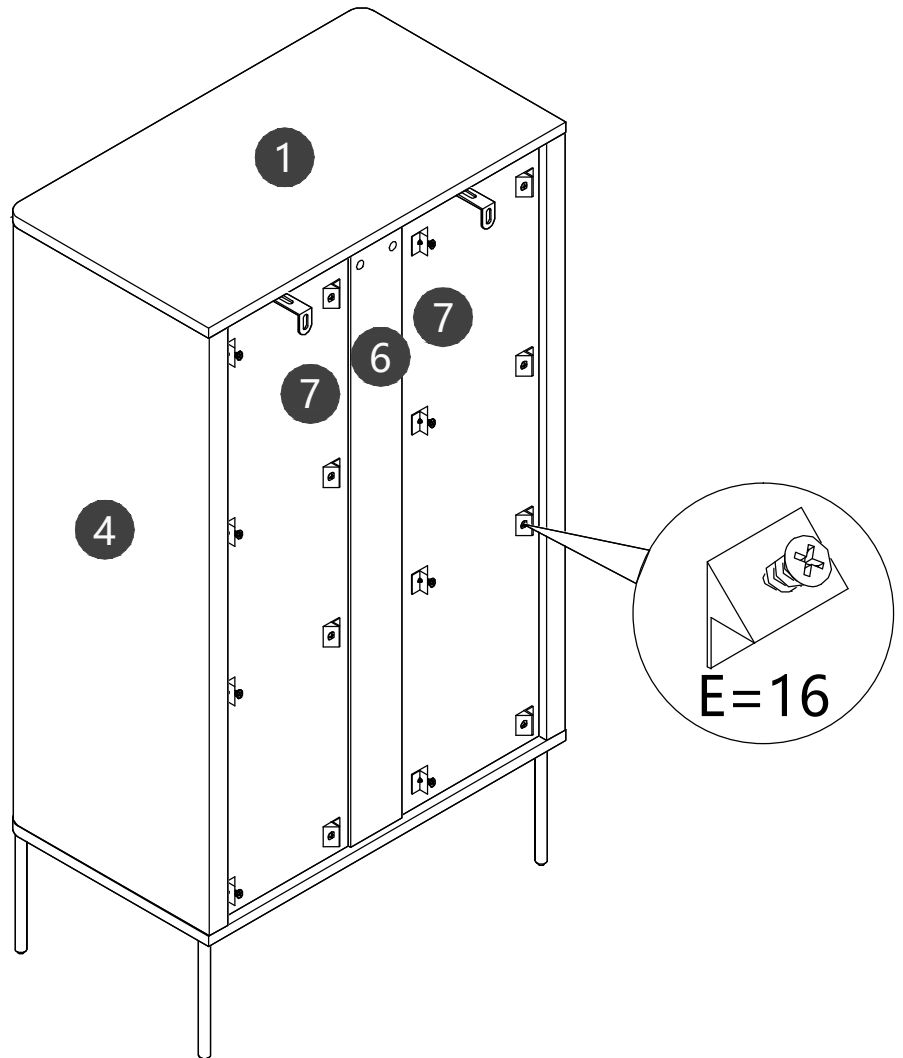

STEP 9

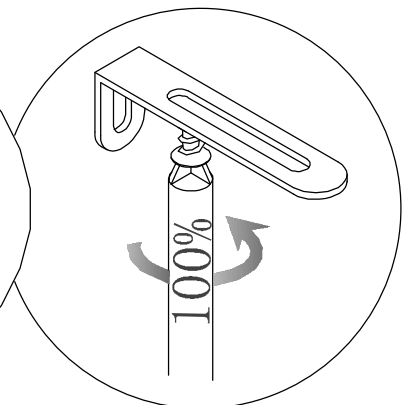
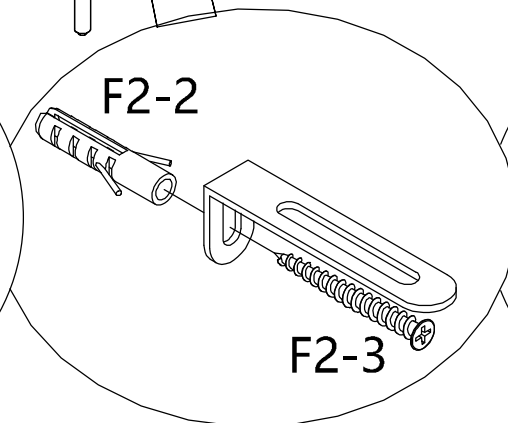
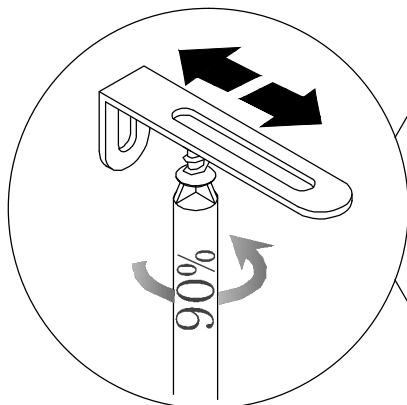
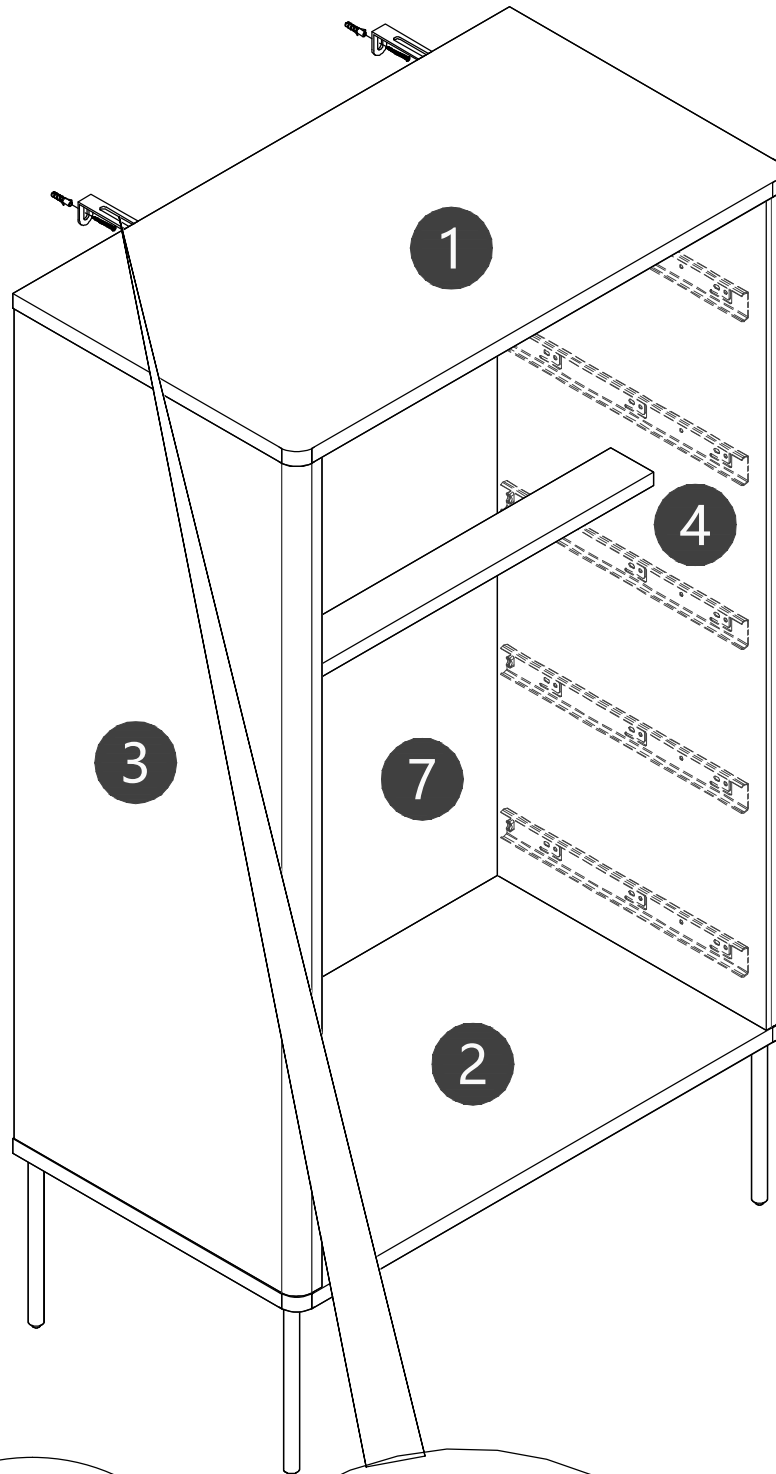

STEP 10

10-1

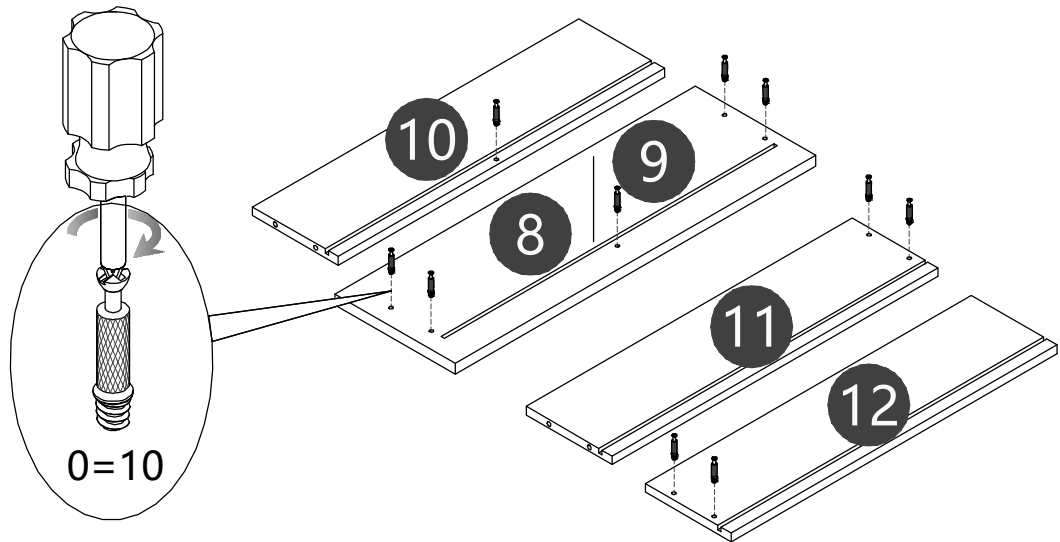

10-2

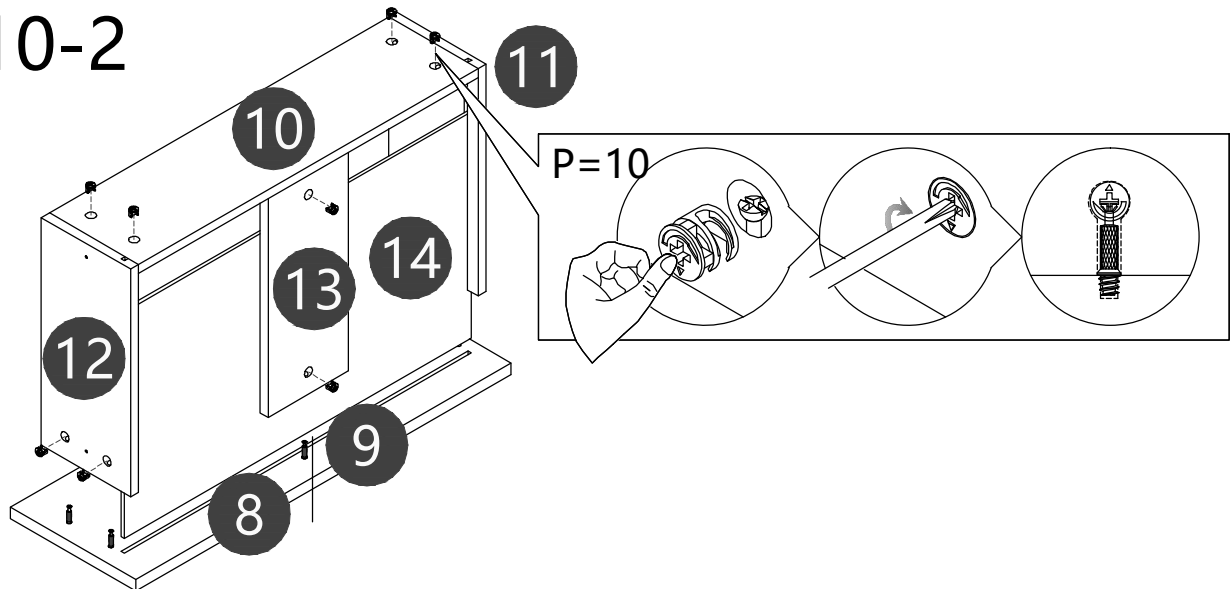

10-3

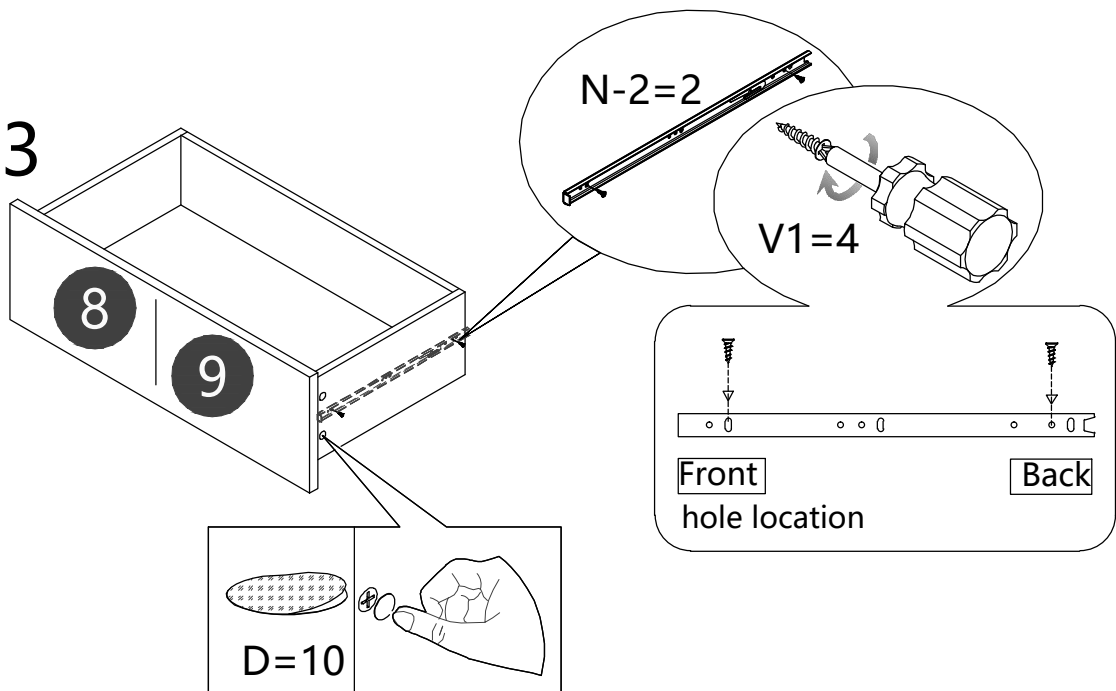

STEP 11

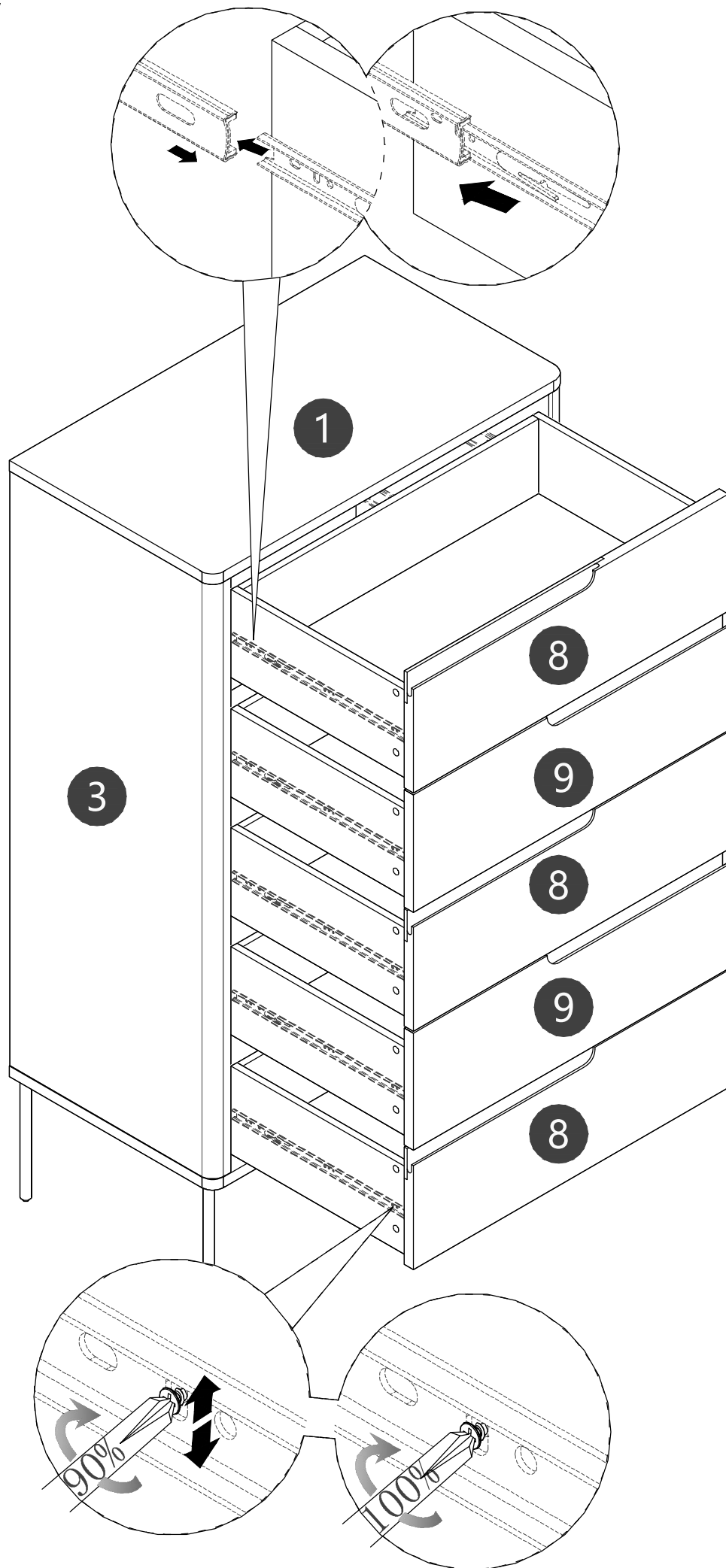

STEP 12



Finish